



MORE LIGHT

Pulse selector IOM 150AC

## Pulse Driver / Pulse Picker Controller for Integrated-Optical Amplitude Modulators

The Pulse Selector IOM is a pulse picker controller for a reliable reduction of high pulse laser repetition rates. It can be used as triggered pulse generator for modulator driving too. The preferred modulator type is JENOPTIK AMxxx b.

For normal operation, the Pulse Selector IOM requires only the synchronizing signal of the laser source. It is controlled by PC via the USB port using a command set. An integrated photo diode enables the use of a feed-back loop for automatic bias control of the modulator.

### Benefits

- Short rise times
- High extinction
- High repetition rate
- Automatic bias-control

### Application

- Reduction of laser pulse repetition rate in oscillator-amplifier systems

# Pulse driver/Pulse picker controller for integrated-optical modulator

## Pulse selector IOM 150AC

### Specifications

Usable modulator type	Jenoptik AMxxx (xxx: wavelength in nm)
Trigger repetition rate	Max. 150 MHz
Trigger input	AC coupled, 50 Ohms, SMA(f) Trigger level adjustable between 50 mV and 3 V Minimum trigger pulse width 3 ns
Division factor	2, 3, 4, ... 65535 (Trigger repetition rate < 80 MHz) 3, 4, 5, ... 65535 (Trigger repetition rate > 80 MHz)
Delay	0 ... 1,048,535 ns, step 1 ns
Modulator opening window	5 ns ... 1,048,535 ns, step 1 ns for division factors > 10 10 ns ... 1,048,535 ns, step 1 ns for division factors > 2 For picking of single pulses or pulse bursts
Output to modulator (RF)	SMA(f), 0 V ... 5.5 V (connected to 50 Ohms) Monitoring output at the rear side (SMA(f))
Output to modulator (bias)	SMC(m), - 10 V ... 10 V (connected to high-resistance input)
Interface to computer	USB (emulated RS232)
Manual operation	Value input via PC Handling by terminal-software, IOM Control demo software
Automatic operation	Automatic operation point control by a feed-back loop possible Modulators pulse suppression > 500 : 1
Feed-back	Internal InGaAs-photodiode, bandwidth 1 GHz, FC-receptacle 1000 nm ... 1600 nm
Mains	85 ... 264 V ac, 50 ... 60 Hz
Storage / Transport temperature	- 20 °C ... 60 °C
Operation temperature	10 °C ... 40 °C
Dimensions (W x D x H)	330 mm x 268 mm x 73 mm

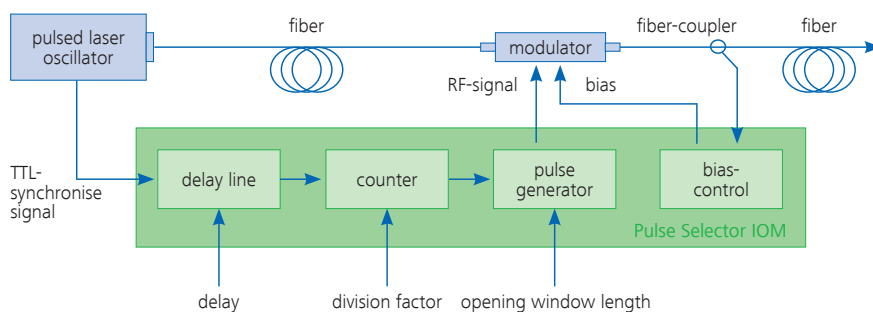

Application scheme

It is our policy to constantly improve the design and specifications. Accordingly, the details represented herein cannot be regarded as final and binding.